

Identification Data



March 4, 2022

LAB GROWN DIAMOND
Certificate No: 320490280

Gemprint™ *The fingerprint system for diamonds®*



Gemprint is the unique optical identification fingerprint of your lab grown diamond. Register your lab grown diamond fingerprint at www.Gemprint.com and receive insurance discounts up to 10%.

Laser Inscription

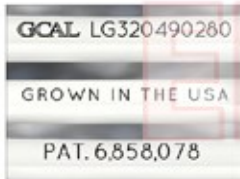

Girdle laser inscribed:
GCAL LG320490280
GROWN IN THE USA
PAT. 6,858,078
This illustration depicts the approximate appearance of the inscriptions

Certified
**SUSTAINABILITY RATED
DIAMOND**
SCS GLOBAL SERVICES

All certified diamonds come with an individual certificate, ONLY available at an accredited retailer



FOR THE SUSTAINABILITY RATED CERTIFICATE, SCAN HERE →

The 4Cs Grading Analysis

GCAL 320490280

LAB GROWN DIAMOND*

Carat Weight:

1.08

Cut:

Excellent

Shape:

Princess

Measurements:

5.58x5.55x3.90mm

Optical Brilliance:

Excellent

Optical Symmetry:

Very Good

Polish:

Excellent

External Symmetry:

Excellent

Girdle Thickness:

SI.Thick

Culet Size:

None

Color:

I

Fluorescence:

None

Clarity:

S11

Identifying Characteristic(s):

Feathers/Clouds

Characteristic Location(s):

Crown Shoulder-Crown Step/Table

*Comments: This laboratory grown diamond was created by the CVD (Chemical Vapor Deposition) method, and has the same chemical, physical, and optical properties as a mined diamond. This diamond is Type IIa, which means it is devoid of nitrogen impurities. As Grown - No evidence of post-growth treatment was detected.

Photomicrographs:

Actual images of the crown (top) and pavilion (bottom) of this diamond photographed at magnifications up to 10x.



Light Performance Profile

Optical Brilliance Analysis:

Brilliance is the overall return of light to the viewer. The brilliance image is a representation of (a) white areas of light return, or brilliance, and (b) dark-blue areas of light loss.

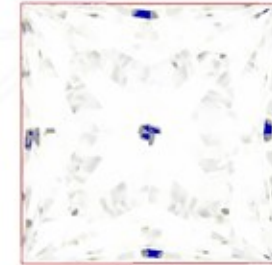

Optical Brilliance
Excellent

Optical Symmetry Analysis:

The colored areas of the symmetry image are indications of light handling ability, giving a visual representation of proportions and facet alignment.

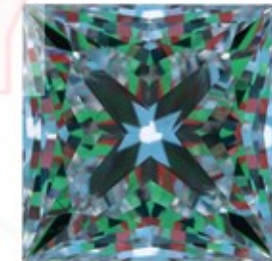

Optical Symmetry
Very Good

Proportion Diagram:

The proportion diagram illustrates the actual dimensions as recorded by optical scanning technology.

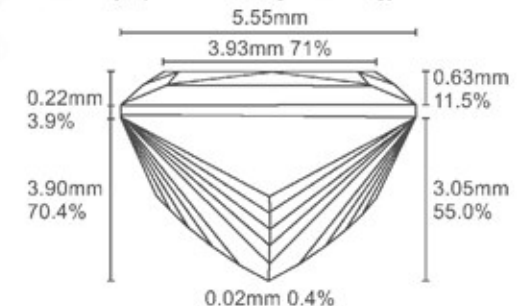

GCAL GEM CERTIFICATION & ASSURANCE LAB
ISO 17025 ACCREDITED FORENSIC LABORATORY

580 Fifth Ave LL-05
New York, NY 10036
T 212-869-8985
GCALUSA.com



ISO/IEC 17025 2017
ANAB L2177-1 Accredited Testing Lab